



**CURRICULUM AND INSTRUCTIONAL SERVICES  
MATHEMATICS COMMON ASSESSMENT REVIEW  
MATH APPLICATIONS (330512)**

Name \_\_\_\_\_ School \_\_\_\_\_

**CALCULATOR ALLOWED  
Part 1**

1. Find the perimeter of the following figure:

1. \_\_\_\_\_

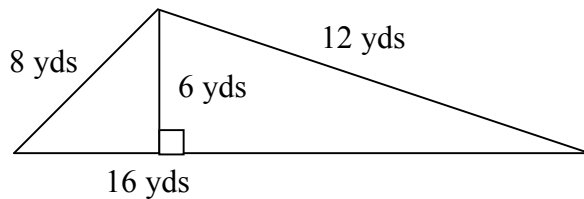

2. Find the area of the figure above.

2. \_\_\_\_\_

3. Find the length of the missing side for the following triangle:

3. \_\_\_\_\_

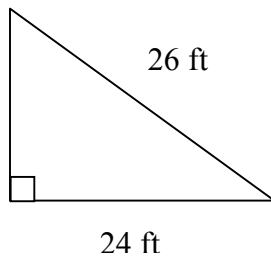

4. Find the length of the missing side for the following triangle:

4. \_\_\_\_\_

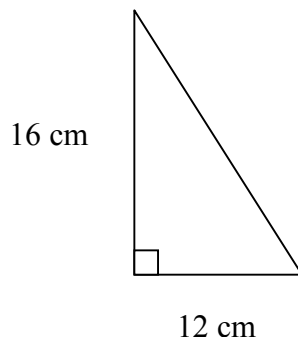

5. Find the length of the hypotenuse for the following triangle:  
**(Round to the nearest thousandth.)**

5. \_\_\_\_\_

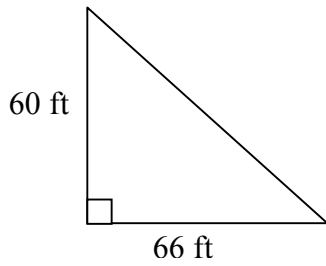

6. Find the measure of the indicated angle.

6. a=\_\_\_\_\_

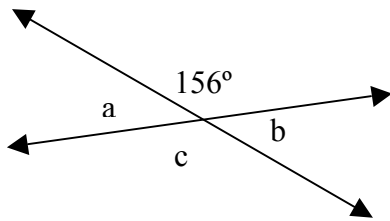

b=\_\_\_\_\_

c=\_\_\_\_\_

7. Name the following angle using the correct notation:

7. \_\_\_\_\_

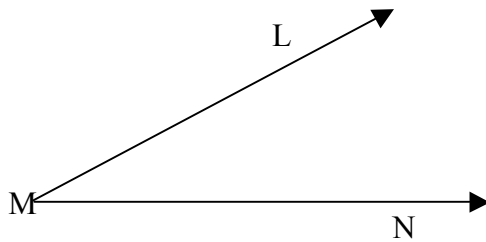

8. Find the angle rounded to the nearest tenth of a degree.  
 $\sin x = 0.8349$

8. \_\_\_\_\_

9. Find the value of the trigonometric ratio using your calculator. Round answer to three decimal places.  
 $\tan 31.3^\circ$  9. \_\_\_\_\_
10. Express in degrees and minutes.  
 $65.6^\circ$  10. \_\_\_\_\_
11. Express in degrees.  
 $\frac{3\pi}{4}$  11. \_\_\_\_\_
12. Express in radians. (Round to three decimal places.)  
 $110.20^\circ$  12. \_\_\_\_\_
13. Solve the following equation using the Square Root Property:  
 $3x^2 = 108$  13. \_\_\_\_\_
14. Solve and check the system of equations below. If the system is inconsistent or dependent, say so.  
 $2x - y = -1$   
 $-4x + 2y = 7$  14. \_\_\_\_\_
15. In a dc circuit the power  $P$  dissipated in the circuit is given by the equation  $P = R \cdot I^2$  where  $R$  is the circuit resistance in ohms and  $I$  is the current in amperes. What current will produce 3180 watts of power in a 40-ohm resistor? 15. \_\_\_\_\_

Use the figure shown for the questions #16 and #17.

16. Find the volume of the figure.

16. \_\_\_\_\_

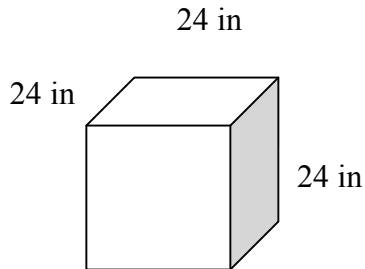

17. Find the total surface area of the figure.

17. \_\_\_\_\_

The following double bar graph represents the number of students enrolled in the welding and Machine Technology program at a community college:

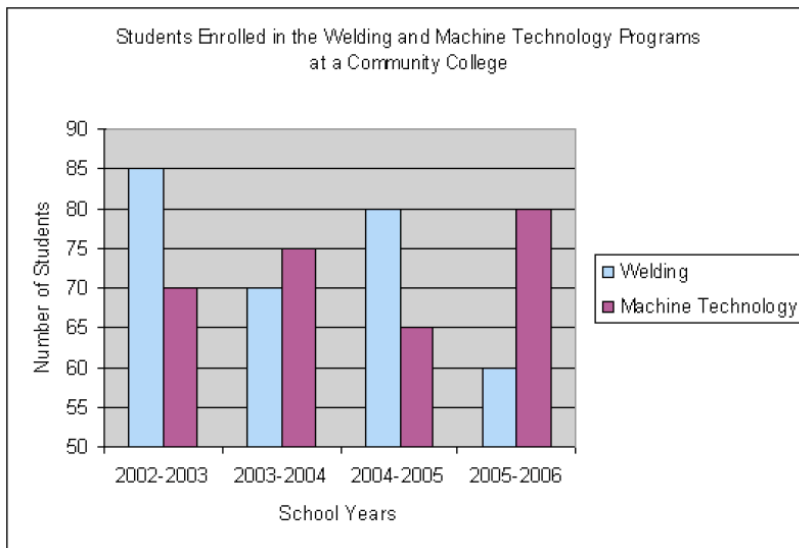

Use the chart to answer the following questions:

18. Which year saw the highest enrollment in the Machine Technology Program, and which year saw the lowest enrollment?

18. \_\_\_\_\_

19. Which year saw 65 students in the Machine Tech Program and 80 students in the Welding Program?

19. \_\_\_\_\_

The following line graph represents data pertaining to water flows over a dam:

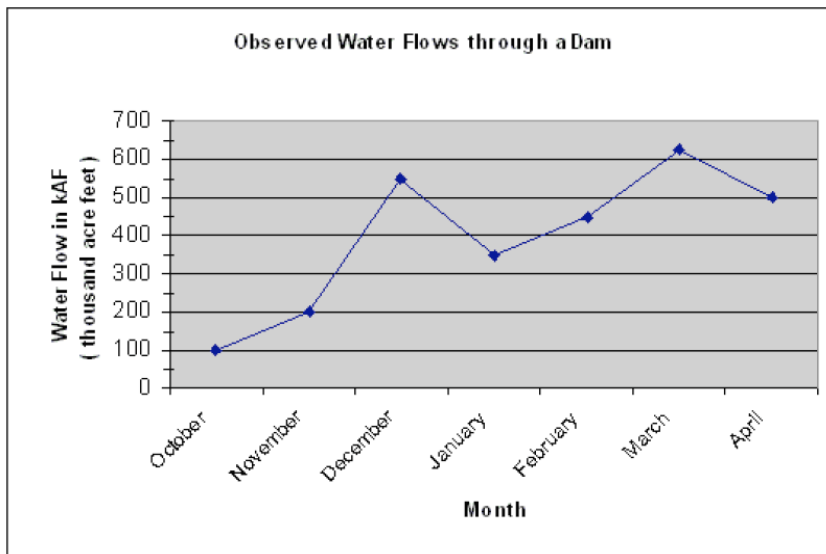

Use the graph to answer the following questions:

20. Which month saw the highest water flow, and which saw the lowest? 20. \_\_\_\_\_
21. During which months did the flow increase? 21. \_\_\_\_\_
22. Which months saw flows of 450 kAF and 550 kAF, respectively? 22. \_\_\_\_\_

The following pie graph represents the breakdown of the battery market in the United States:

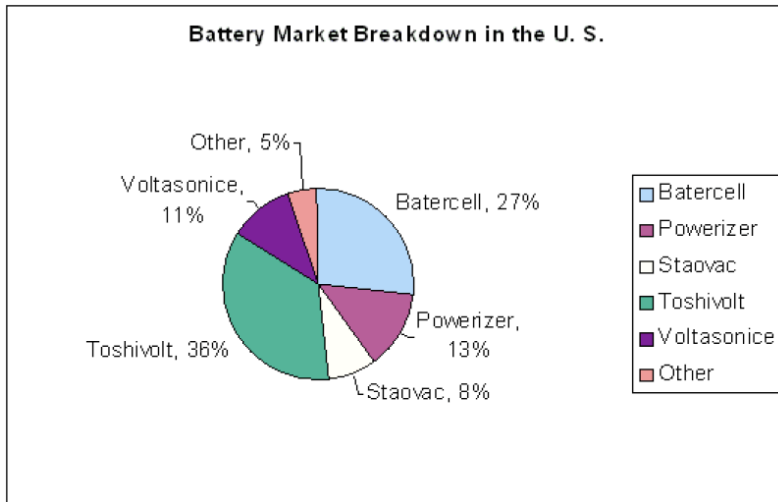

Use the graph to answer the following questions:

23. Which battery has the smallest share of the market?

23. \_\_\_\_\_

24. Which battery has 13% of the market?

24. \_\_\_\_\_

**Part 2**

**SHORT ANSWER**

*Show all work in the space provided or on a separate sheet of paper.*

25. Find the area of the following trapezoid:

25. \_\_\_\_\_

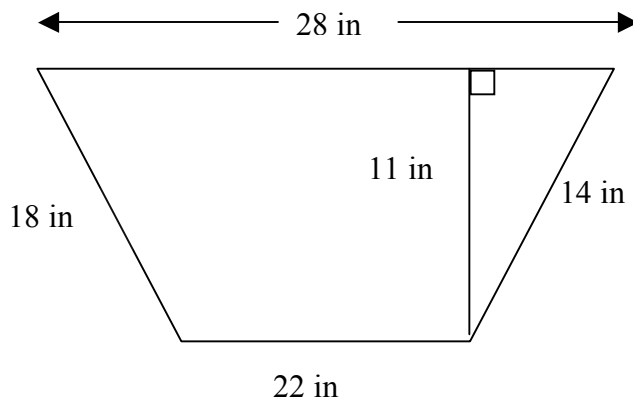

26. Find the area of the following figure. Round to the nearest tenth, if necessary. (Each side of the figure is 45 in.)

26. \_\_\_\_\_

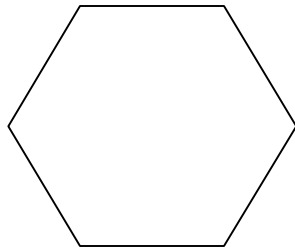

27. Find the area of the ring. The radius of the large circle is 12 m and the radius of the smaller circle is 8 m.

27. \_\_\_\_\_

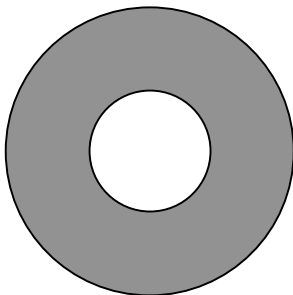

28. Solve the following right triangle:  
 (Round all angles to the nearest tenth of a degree and all sides to the nearest tenth of a unit, if necessary.)

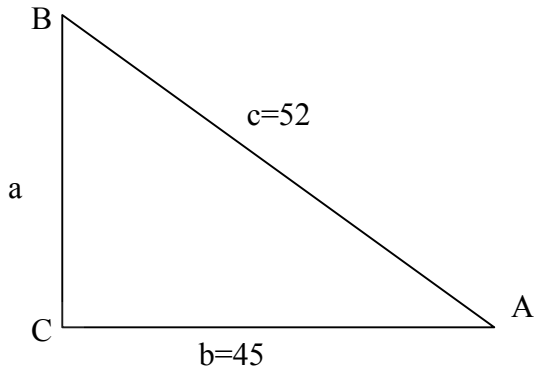

28.  
 $a =$  \_\_\_\_\_  
 $m\angle A =$  \_\_\_\_\_  
 $m\angle B =$  \_\_\_\_\_  
 $m\angle C =$  \_\_\_\_\_

29. Solve the following right triangle.  
 (Round all angles to the nearest tenth of a degree and all sides to the nearest tenth of a unit, if necessary.)

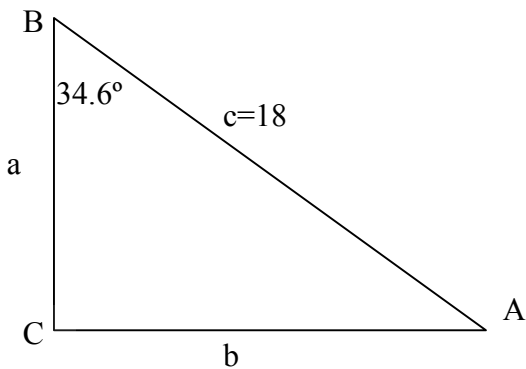

29.  
 $a =$  \_\_\_\_\_  
 $b =$  \_\_\_\_\_  
 $m\angle A =$  \_\_\_\_\_  
 $m\angle C =$  \_\_\_\_\_

30. Solve the following equation using the Square Root Property:

$$8x^2 - 7200 = 0$$

30. \_\_\_\_\_

31. A rectangular flower bed is 16 feet longer than it is wide.  
If the area of the flower bed is 132 square feet, find the width and the length of the flower bed.

31.  
L= \_\_\_\_\_  
W= \_\_\_\_\_

32. Solve and check the following system of equations. If the system is inconsistent or dependent, say so.

$$2x + 3y = 7$$
$$8x - 6y = 10$$

32. \_\_\_\_\_

33. Solve and check the following system of equations. If the system is inconsistent or dependent, say so.

$$x + 4y = -24$$
$$-x - 6y = 40$$

33. \_\_\_\_\_

34. Solve and check the following system of equations. If the system is inconsistent or dependent, say so. 34. \_\_\_\_\_

$$-3x + y = -5$$

$$12x - 4y = 20$$

35. How much 5% alcohol solution should be mixed with a 15% alcohol solution to get 4 liters of 12% alcohol solution? 35. \_\_\_\_\_

36. Solve the following quadratic equation using the quadratic formula (Round to two decimal places if necessary.) 36. \_\_\_\_\_

$$-4x^2 - 10x + 6 = 0$$

37. Solve the following quadratic equation using the quadratic formula. (Round your answer to two decimal places if necessary.) 37. \_\_\_\_\_

$$-x^2 + 5 = 4x$$

Use the figure shown for the questions #38, #39, and #40.

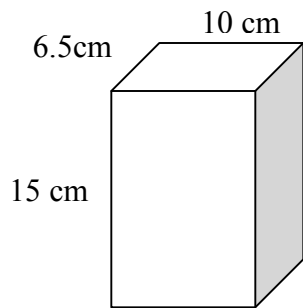

38. Find the **lateral** surface area of the figure.

38. \_\_\_\_\_

39. Find the **total** surface of the figure.

39. \_\_\_\_\_

40. Find the **volume** of the figure.

40. \_\_\_\_\_

Use the figure below for questions #41 and #42.

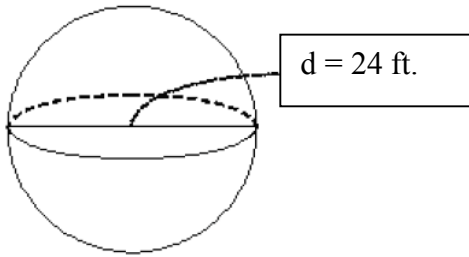

41. Find the **volume** of the figure.

41. \_\_\_\_\_

42. Find the **total** surface area of the figure.

42. \_\_\_\_\_

Use the figure below for questions #43 and #44.

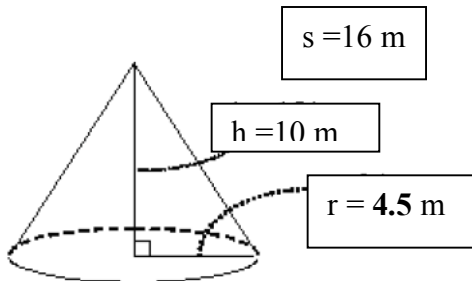

43. Find the **volume** of the figure. (Round to the nearest tenth.)

43. \_\_\_\_\_

44. Find the **total** surface area of the figure. (Round to the nearest hundredth.)

44. \_\_\_\_\_

### Part 3

#### APPLICATIONS

*Show all work in the space provided or on a separate sheet of paper.*

45. Sheet Metal Trades

A rectangular opening 24 in. wide must have the same total areas as two smaller rectangular vents 8 ft. by 5 ft. and 11 ft. by 4 ft. What must be the height of the opening?

45. \_\_\_\_\_

46. Printing

A sheet of 11-in. by 17-in. paper must be cut into 3-in. by 5-in. cards. The cuts can be made in either direction, but they must be consistent. Which plan will result in the least amount of waste: cutting the 3-in. side of the card along the 11-in. side of the sheet or along the 17-in side of the sheet? State the amount of waste that was created by each possibility. (*Hint: Make a cutting diagram for each possibility.*)

46. \_\_\_\_\_

47. Interior Design

The floor plan of a room is shown in the figure. If the entire room is to be carpeted, how many square *yards* of carpet are needed? At \$24.95 per square yard, how much will it cost?

47. \_\_\_\_\_



48. Carpentry

Find the diagonal length of the stairway in the drawing.

48. \_\_\_\_\_

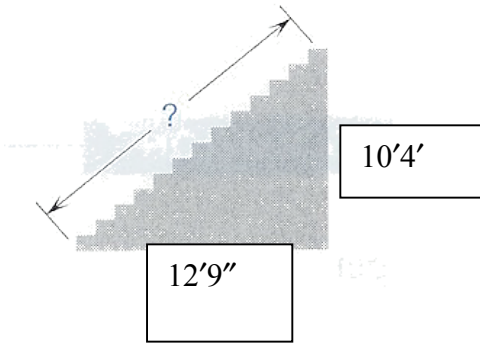

49. Metalworking

How many inches apart will eight bolts be along the circumference of the metal plate shown in the figure? Round to the nearest tenth of an inch

49. \_\_\_\_\_

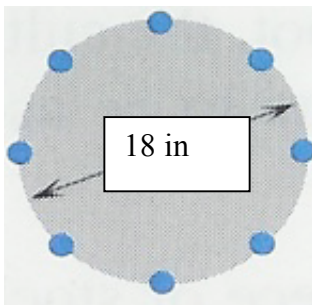

50. Food Services

A medium pizza at Papa's Pizza Place is 12 in. in diameter, and a large pizza is 14 in. in diameter. If a medium pizza will serve four customers, how many servings will a large pizza provide?

50. \_\_\_\_\_

51. Roofing

The roof of a building is in the shape of a pyramid, having a square base 42 ft. on each side. If the slant height of the roof is 54 ft., what is the cost of the roofing material needed at \$0.65 per square ft.?

51. \_\_\_\_\_

52. Manufacturing

Find the capacity in gallons of the oil can in the figure.

52. \_\_\_\_\_

(1 gallon = 231 in.<sup>3</sup>)

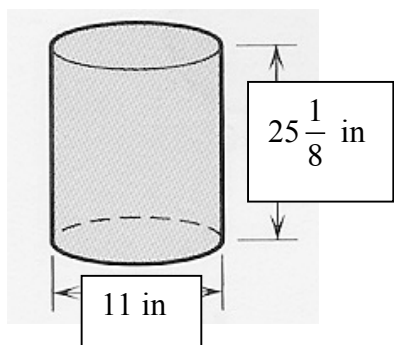

53. Industrial Technology

How high should a 40-gallon cylindrical tank be if it must fit into an area allowing at 26-in. diameter?

53. \_\_\_\_\_

54. Plumbing

54. \_\_\_\_\_

A water tower consists of a 15-ft.-high cylinder and a 9-ft.-radius hemisphere. How many gallons of water does it contain when it is filled to the top of the cylinder? Round to the nearest hundred ( $1 \text{ ft}^3 = 7.48$  gallons)

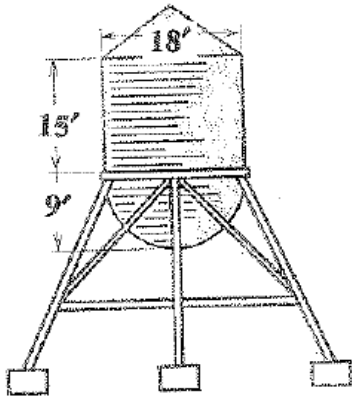

55. Construction

55. \_\_\_\_\_

The outfield fencing for a Little League field forms a circular sector with home plate as the center. The fence is placed at a uniform distance of 240 ft. from home plate. The boundaries of the fence, which extend partway into foul territory, create an angle of  $105^\circ$  with home plate. At \$24 per foot how much will the fence cost? Round to the nearest \$10.

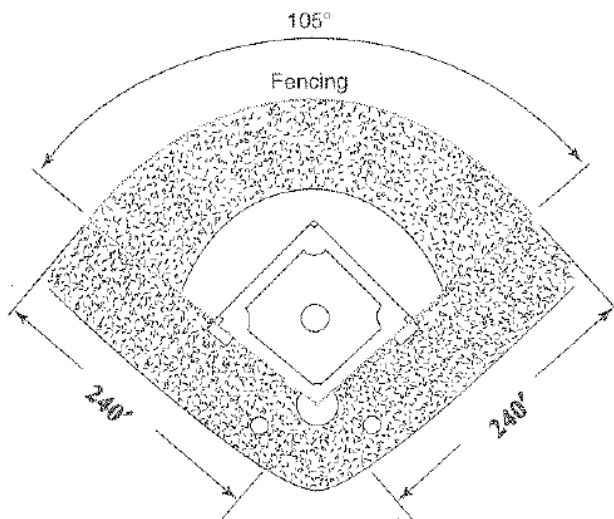

56. Aviation

56. \_\_\_\_\_

A helicopter, flying directly over a fishing boat at an altitude of 1500 ft., spots an ocean liner at a  $20^\circ$  angle of depression. How far from the boat is the liner? Round to the nearest foot.

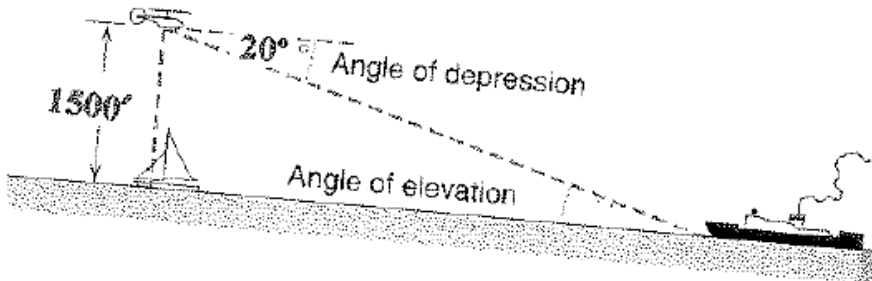

57. Masonry

57. \_\_\_\_\_

A 30-ft. ladder leans against a building at a  $70^\circ$  angle with the ground. Will it reach a window 25 feet above the ground? Explain your answer.

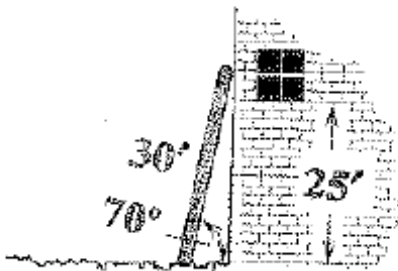

58. Police Science

58. \_\_\_\_\_

Detectives investigating a crime find a bullet hole in a wall at a height of 5 ft. 4 in. from the floor. The bullet passes through the wall at an angle of  $26^\circ$ . If they assume that the gun was fired from a height of 2 ft. above the floor, how far away from the wall was the gun when it was fired? Round to the nearest foot

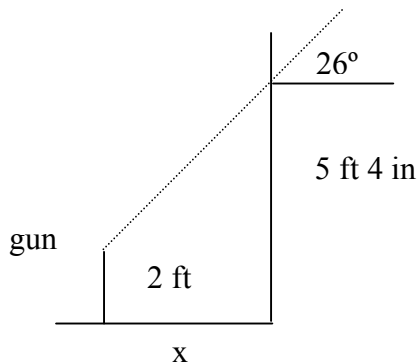

59. A TV technician installs a 35-ft. antenna on a flat roof. Safety regulations require a minimum angle of  $25^\circ$  between mast and guy wires.

59. A. \_\_\_\_\_

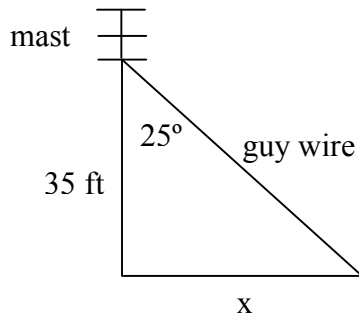

A. Find the minimum value of  $x$ .

B. \_\_\_\_\_

B. Find the length of the guy wires.

60. Automotive Trades

60. \_\_\_\_\_

The fuel economy  $E$  (in miles per gallon) of a certain vehicle is given by the formula:  $E = -0.0088v^2 + 0.75v + 14$  where  $v$  is the average speed of the vehicle (in miles per hour).

What average speed must be maintained in order to have a fuel economy of 32 mi/gal? Round to the nearest mile per hour.

61. Police Science

To determine the speed that a vehicle was traveling at the time of an accident, police officers carefully measure the length of the skid marks left at the scene. There are many factors that determine the skid length, and a quick and simple formula for determining speed is

$S = \sqrt{30 \cdot L \cdot d \cdot e}$ , where  $S$  is the speed in miles per hour,  $L$  is the skid length in feet,  $d$  is the drag factor, and  $e$  is the braking efficiency. The following table shows the skid lengths for 10 accidents that occurred on a particular stretch of an interstate during icy conditions this past winter:

- A. Use the given formula with  $d = 0.2$  (icy road) and  $e = 1.0$  to calculate the speed for the given skid lengths and fill in column 2. Round to the nearest whole number.

(Hint: Use speed data for  $x$ )

SKID LENGTH, $L$	SPEED, $S$ (MPH)	$(x - \bar{x})$	$(x - \bar{x})^2$
415			
252			
694			
518			
382			
617			
508			
296			
635			
471			

Sum = \_\_\_\_\_

Sum = \_\_\_\_\_

- B. Find the median speed.

B. \_\_\_\_\_

- C. Find the mean speed  $(\bar{x})$ .

C. \_\_\_\_\_

- D. Find the range of the speeds

D. \_\_\_\_\_

- E. Find the standard deviation of the speeds.

E. \_\_\_\_\_

$$S = \sqrt{\frac{\text{sum of } (x - \bar{x})^2}{n}}$$

62. Sales

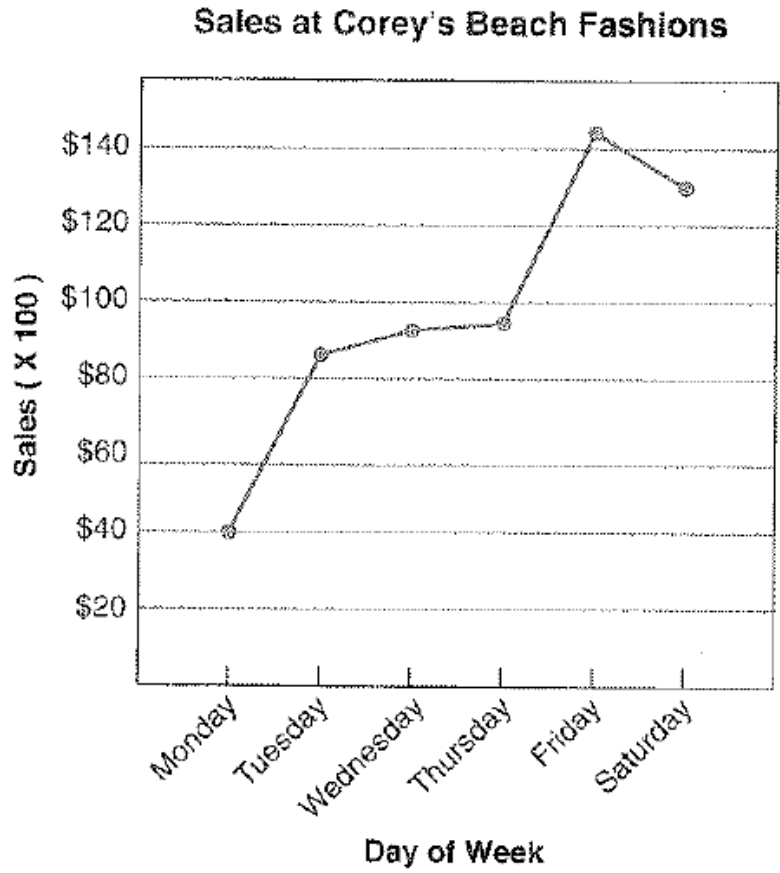

- A. On what day are sales at Corey's highest? A. \_\_\_\_\_
- B. Calculate the percent increase in sales from Monday to Thursday. B. \_\_\_\_\_
- C. On what days are sales above \$10,000? C. \_\_\_\_\_
- D. When should Corey's concentrate their effort on improving sales and why?

---



---



---



---